

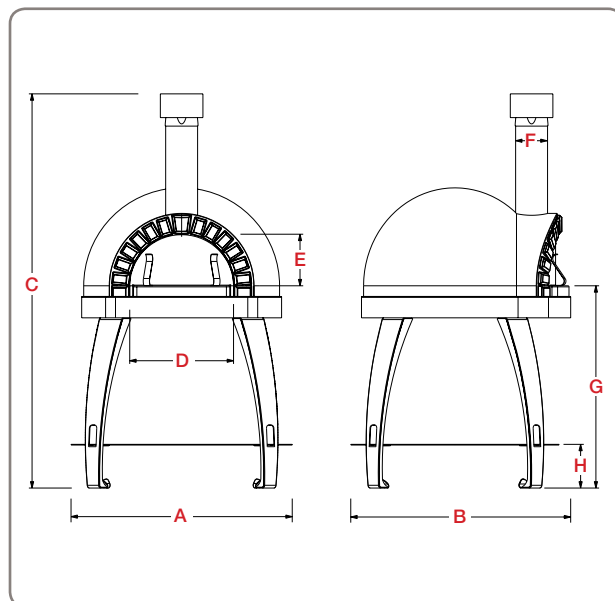

MISURE / DIMENSIONS



CARATTERISTICHE TECNICHE / TECHNICAL DETAILS

Peso / Weight	200 Kg / 440,9 Lbs		
Area piano forno / Oven floor area	Diametro interno / Inside diameter	0,4 m ² / 4,3 ft ²	70 cm / 27,5 In
Minuti per scaldare / Heating time	45		
N° pizze alla volta / Pizza capacity	3		
Infornata di pane / Bread capacity	6 Kg / 13,2 Lbs		
Consumo medio / Average fuel consumption	3,5 Kg/h / 7,7 Lbs/h		
Temperatura massima / Max oven temperature	400 °C 752 °F		
Combustibile consigliato / Recommended fuel	Ciocchi diam. max. 10 Cm, potature / Max. 3,9 In diam. logs, trimmings		

MISURE / DIMENSIONS

A	Larghezza totale / Total width	104 Cm / 40,9 In
B	Lunghezza totale / Total length	103 Cm / 40,5 In
C	Altezza totale / Total height	185 Cm / 72,8 In
D	Larghezza bocca / Oven mouth width	49 Cm / 19,3 In
E	Altezza bocca / Oven mouth height	24 Cm / 9,4 In
F	Diametro cappa / Chimney diameter	15 Cm / 5,9 In
G	Altezza piano cottura / Oven floor height	95 Cm / 37,4 In
H	Altezza ripiano / Shelf height	21 Cm / 8,2 In

MONTAGGIO e componenti / ASSEMBLY and parts list

	Cod.	N°	Desc.
a	XFCCUP	1	Cupola forno
b	XFPCUPA	1	Piano forno anteriore
c	XFPCUPD	1	Piano forno posteriore
d	XCSCUP	1	Struttura forno Cupola
e	XRFCUP	1	Ripiano forno Cupola
f	XCFUCUP	1	Canna fumaria
g	XCOMICUP	1	Comignolo
h	YSPOCUP	1	Sportello forno

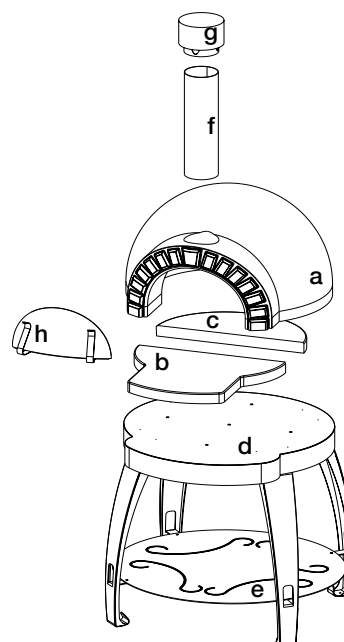

N.B. Seguire l'ordine alfabetico per il montaggio del forno.